

50:1 GREASE PUMP

PART NO 25740



2011-06 ORIGINAL MANUAL SERVICE GUIDE



General

Thank you for choosing a high quality pump from Eurolube Equipment AB Sweden. The 50:1 grease pump features an unique air motor for quiet and quick serviceability. Recommended for heavy duty units and large pipe installations, to dispense greases with a viscosity up to NLGI 2. Please refer to the sales catalogue for details on accessories. Or visit our website, www.eurolube.com.

The 50:1 ratio grease pump is suitable for simultaneous fluid distribution to multiple dispense points, or for pumping to distances of up to 90m (300ft). The air motor features a precision air valve mechanism with dual valve ports for improved high speed breathing. It also contains a positive trip detent spool mechanism that eliminates stalling (blowing air) by preventing the pump from stopping between strokes. It has a simple yet durable construction with all internal parts lubricated at the factory using a life-tested synthetic grease.

The pumping assembly features a stainless pump rod for superior wear and corrosion resistance. The pump's exterior is constructed from aircraft grade aluminum for an outstanding strength and reliability. The pump also has high quality seals and is designed for long-term durability and ease of service. It also features a double action grease pumping assembly, which provides volume delivery on both strokes.

A pump's ability to deliver grease is based on the pressure (bar/psi) and quantity of air supplied to the air- motor and the amount of material discharge (back) pressure to be overcome within the system.

WARNING! Do NOT use solvents or other explosive fluids. An explosion can result in the pump when aluminium and zink parts come in contacts with certain solvents. Never point a control valve at any portion of your body or another person. Accidental discharge of pressure and/or material can result in injury. Read these instruction carefully before installation, operation or service.

DO NOT EXCEED MAXIMUM PRESSURE

TECHNICAL DATA / TEKNISKA DATA

PART NO	25740
Pump ratio	50:1
Maximum air pressure	10bar (150psi)
Recommended air pressure	2,8-8,6bar (40-125 psi)
Minimum air pressure	0,7bar (10 psi)
Air motor effective piston diameter	107mm (4,2")
Nominal pump stroke length	81,3mm (3,25")
Pump cycles per Pound @ 7 bar (100 psi) air pressure	55-67 cyc/kg (20-24 cy/lb)
Fluid stall pressure @ 10 bar (150 psi) air pressure	521bar (7550 psi)
Approx air consumption @ 7 bar (100 psi) air pressure	480 l/min per 450g pumped (17 SCFM per pound pumped)

Operating Noise Level

85 DbA @ 7 bar (100 psi) air and 1,4kg/min (3 lbs/min)



NOTE: This pump has been tested and found conforming to OSHA operating noise limits when used for intended purpose (grease dispensing, intermittent duty cycles).

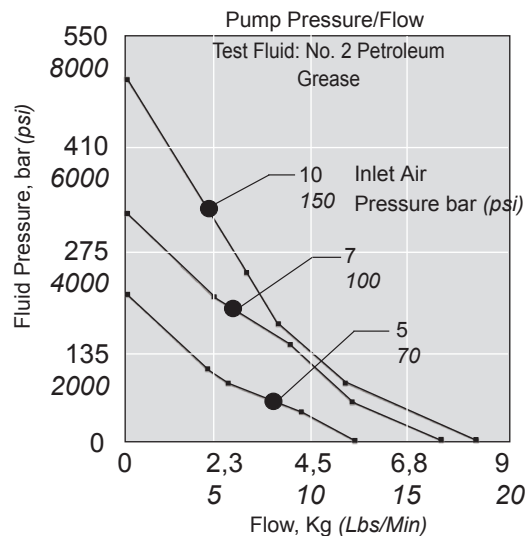

50:1 GREASE PUMP

PART NO 25740

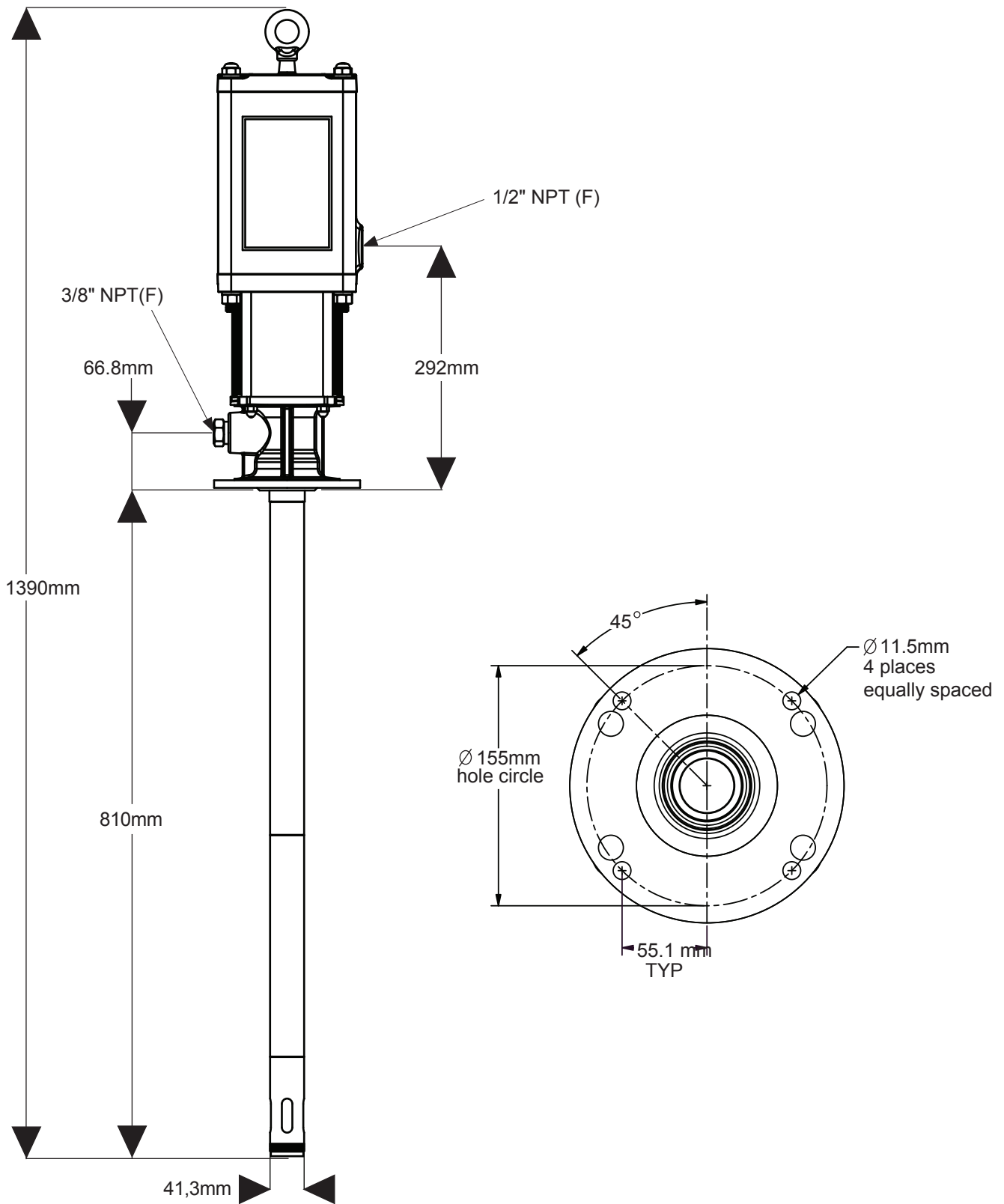

Figure 12
Complete Pump
Dimensions & Features

50:1 GREASE PUMP

PART NO 25740

PUMP INSTALLATION



WARNING: Attach a proper ground wire to the pump grounding lug (item 62) before starting the pump.



CAUTION: Performance will be affected by a suction path seal (follower plate) that is not air tight.

To ensure proper performance of your grease pump, Eurolube recommends using a follower plate if mounting the pump to a grease drum.

Using four M10 (3/8"-16) bolts and lock washers, secure the pump to the drum cover. Slide the follower plate up the pump tube and attach optional screen assembly. Insert pump (with follower plate) into drum and tighten thumb screws.

Tighten one end of outlet hose to pump outlet. Secure control handle to the other end of the outlet hose. Install a coupler or a ball valve into the pump's air intake port. Attach a F-R-L onto the pump. Fill the lubricator with 10-20 wt. lubricant - set for 1 drop every 2 hours. Connect compressed air to F-R-L and set regulator to no more than 10 Bar (150 psi).

Open control handle into suitable container to properly prime pump and remove air from system.

PREVENTIVE MAINTENANCE

The grease pump has been designed to operate dependably with little required maintenance. However, to ensure pump longevity, the following should be observed:

- Keep the grease free of trash and debris. Periodically check the pump inlet for foreign matter and clean when necessary.
- Run the pump at the minimum pressure required to achieve the desired flow rate (less than 8 bar (125 psi) and 150 cyc/min recommended).
- Ensure the pump receives clean, moisture free air. Check and maintain the system's air filter on a regular basis.
- Although the air motor is coated with synthetic grease upon factory assembly and can run without lubricated air, Eurolube recommends an in-line F.R.L. be installed in the pumping system.
- Never let the pump run dry of the grease being pumped.

PUMP OPERATION

TO START PUMP:

1. Immerse the pump's suction tube inlet into the grease to be pumped.
2. Connect the air coupler to the pump and turn the air regulator to the minimum setting.
3. Direct pump outlet hose into an approved waste oil container.
4. Slowly adjust the air regulator until the pump is primed and running smoothly. Be sure all air has been purged from the system. The pump should prime in less than 30 seconds.
5. Use the air regulator to control the pump's speed and cycle rate. Always use the lowest pressure required to obtain the desired flow rate. This will increase pump and seal life.
6. Never allow a pump to be run dry of the grease being pumped. A dry pump quickly speeds up, which could damage the air motor and fluid seals. If the pump suddenly speeds up, cut off the air supply as soon as possible, refill the reservoir with grease and reprime the pump.
7. If the pump will be unattended for any period of time, or to shut off the system at the end of a work shift, always relieve the pump's pressure.

PUMP REPAIR / SERVICING

PUMP DISASSEMBLY PROCEDURE:

FIGURE 11

1. Mount the pump horizontally in a bench vise. Clamp the vise to the upper body of the pump and use elastic jaw cushions in the vise to prevent scarring the pump surface. With a socket wrench, loosen and remove the four lower 5/16" Hex Bolts [14] and Lock Washers [12]. Then remove and set aside the Bare Lower subassembly. Also remove the Lower Body [4], Muffler [17], and Diffuser Plate [16].
2. If the air motor subassembly will not be repaired immediately, re-attach the Lower Body [4], Muffler [7], and Diffuser Plate [16] to the Air Motor subassembly, temporarily securing them with the 5/16" Bolts [14] and Lock Washers [12], turned hand tight. Remove the assembly from the vise.
3. For further disassembly, use the separate procedures which follow for the Air Motor and Lower Pump subassemblies.

AIR MOTOR DISASSEMBLY PROCEDURE:

FIGURE 5

4. If the Lower Body [4], Muffler [17], and Diffuser Plate [16] are attached to the Air Motor subassembly, remove them now, along with the four 5/16" Hex Bolts [14] and Lock washers [12] which secure them.
5. Mount the Air Motor horizontally in a bench vise. Clamp the vise to the Upper Body [2] of the pump and use elastic jaw cushions in the vise to prevent scarring the pump surface.
6. Using a socket wrench, hold the 1/2" Hex Acorn Nut [11] on the pump Cap [1]. With a second socket wrench, loosen and remove the 1/2" Hex Nut [10] and Lock washer [9] at the other end of the 1/2"-13 Threaded Stud [7]. Then remove the Acorn Nut [11] and Stud [7] as a group. Do not remove the Acorn Nut from the Threaded Stud. Repeat the procedure for the other three Studs. Set aside all fasteners in a group.
7. Remove the Center Insert [3] from the subassembly by sliding it carefully off the Air Piston. Remove the two O-ring Seals, [5] and [26], from their glands on the Center Insert [3]. Set these parts aside in a group.
8. Remove the Cap [1] from the top of the Air Motor. As the Cap [1] is removed, it must be shifted sideways approximately 1 inch to allow detachment from the internal Trip Rod. After removal of the Cap, remove the O-ring Seal [5] from the gland in the Cap. Set these parts aside in a group.

9. Remove the Air Motor Subassembly [shown in figure 4] from the Upper Body [2]. Remove toward the top of the pump, opposite the direction of the 1/2" NPT port on the Upper Body. Slide out carefully, keeping the Air Piston square with the bore of the Upper Body. Remove the Upper body from the vise and set aside.

FIGURE 4

10. Remove the O-Ring Seal [6] from the Air Piston [18]. Using a flat blade screwdriver, remove two Detent Sleeves [29], Detent Springs [28], and Detent Balls [27]. Set all of the removed parts aside as a group.
11. Clamp the Air Piston in a vise applied to the 6" piston diameter. Note! Use Split wood-en vise blocks matched to the piston diameter to prevent scarring the piston surface!
12. Using two open-end wrenches, loosen the Jam Nuts [25] located on top of the Intake Valve Stems [22]. Remove the Jam Nuts and the two Intake Valve Stems. It may be necessary to secure the hex cap of the Valve Stem [22] with an open end wrench while removing the second nut. Then remove the O-Ring Seals [24] from the gland of the two Valve Stems [22].
13. Remove the Valve Trip Assembly [shown in figure 3] from the top of the Air Piston. Remove the Air Piston plus Rod Coupler, items [18] and [19], from the vise and set aside. Note! It is not necessary to separate the joint of the Air Piston and Coupler.

FIGURE 4

14. Secure the assembly horizontally in a bench vise, clamping the parts at the flats located on the Rod Head [33]. Applying torque to the flats of the Retainer, Spring, Threaded [34], loosen the trip rod assembly. Note! Turn wrench slowly and steadily to prevent breaking male threads on the Trip Rod [32].
15. Remove all parts from the Trip Rod [32]. Using vise-grip pliers, clamp the Trip Rod [32] near the Rod Head [33] and loosen the remaining threaded joint. Set aside all loose parts in a group, but retain the Valve Bar parts [shown in Figure 2] for further disassembly.

FIGURE 2

16. Using two open-end wrenches, loosen the Jam Nuts [25] located on top of the Exhaust Valve Stems [23]. Remove the Jam Nuts and the two Exhaust Valve Stems. It may be necessary to secure the hex cap of the Valve Stem [23] with an open end wrench while removing the second nut. Then remove the O-Ring Seals [24] from the gland of the two Valve Stems [23].

50:1 GREASE PUMP

PART NO 25740

17. Clamp the subassembly in a vise on the flats of the Nut [15]. Using an adjustable open-end wrench, loosen the Detent Spool [20]. Separate all parts. Set aside all items from steps 16 and 17 in a group. Disassembly of the Air Motor is now complete.

LOWER PUMP DISASSEMBLY PROCEDURE:

FIGURE 10

1. Clamp the subassembly shown in figure 10 in a bench vise, holding the parts at the flat edge of the flange of the Fluid Adapter [38]. Place a 5/16" punch thru the slats of the Primer Cylinder [46] and thru the hole in the Primer Rod [54]. Using a 1/2" socket remove Nut [59]. Slide Piston [58] off of Primer Rod [54]. Using a strap wrench, remove Primer Cylinder [46]. Set these parts aside after removal.

FIGURE 9

2. With the Fluid Adapter [38] still clamped in the bench vise, remove the Primer Valve [60]. Using a strap wrench remove Pump Tube [44 & 45] together by sliding them out of the Adapter [38]. Use care to avoid scarring the surface finish on the o.d. of the Pump Rod. Using snap ring pliers, remove Retainer Ring [61]. Seal [57] and Seal Retainer [56] can be removed. Set aside the Primer Valve parts and Tubes.

FIGURE 8

3. Using a 5/16" punch and a pipe wrench, detach the Upper Rod [48] from the Lower Rod [49]. Set all parts aside.

FIGURE 7

4. Place a 5/16" punch in a bench vise. Slide the Lower Rod [49] onto the punch. Separate Primer Rod [54] from High Pressure Piston [55] with a 5/16" punch and a 3/8" spinner wrench. Separate High Pressure piston [55] from Piston Nut [51] with two 3/8" spinner wrenches. Separate Piston Nut [51] from Lower Rod [49] with 3/8" spinner wrench. Set all parts aside from figure 7 as a group.

FIGURE 6

5. Clamp the Seal Adapter [39] on the flats in a bench vise. Using an adjustable wrench, remove the Port Extension [47]. Using a pipe wrench, remove the Fluid Adapter [38]. With an adjustable wrench, unscrew Seal Carrier [40] from Seal Adapter [39]. Pull Upper Rod [48] out of Seal Adapter [39]. Slide Rod Guide [42], Seal [43], and Seal Retainer [41] off of Upper Rod [48]. Set all parts aside. Disassembly of the Pump Lower is now complete.

LOWER PUMP ASSEMBLY PROCEDURE

FIGURE 6

1. Collect the parts group shown in figure 6. Substitute rebuild kit parts in place of old items where applicable. Clamp the Seal Adapter [39] on the flats in a bench vise. Apply a film of grease to the o.d. of the Upper Rod [48]. Install the Seal Retainer [41], Seal [43], and Rod Guide [42] onto the Upper Rod [48]. Insert the Upper Rod [48] into the Seal Adapter [39]. Secure with Seal Carrier [40].
2. Attach Fluid Adapter [38]. Re-install Port Extension [47]. Set this subassembly aside.

FIGURE 7

3. Collect the parts group shown in figure 7. Place a 5/16" punch in a bench vise. Slide the Lower Rod [49] onto the punch. Attach Piston Nut [51] with Lower Rod [49] with a 5/16" punch and a 3/8" spinner wrench. Connect High Pressure piston [55] to Piston Nut [51] with two 3/8" spinner wrenches. Connect Piston Nut [51] to Lower Rod [49] with 3/8" spinner wrench. Set this subassembly aside.

FIGURE 8

4. Collect the parts group shown in figure 8. Clamp Fluid Adapter [38] in the bench vise. Attach Upper Rod [48] to Lower Rod [49].

FIGURE 9

5. Substitute rebuild kit parts in place of old items where applicable. With the Fluid Adapter [38] still clamped in the bench vise, install the Upper Tube [44] using a strap wrench. Apply a film of grease to the o.d. of the Lower Rod [49] and slide Primer Valve [60] onto Lower Rod [49]. Use care to avoid scarring the surface finish on the o.d. of the Lower Rod.

FIGURE 10

6. With the Fluid Adapter [38] still clamped in the bench vise, install Primer Cylinder [46] using a strap wrench. Insert Piston [58] and secure with Nut [59]. Lower Pump Assembly is now complete.

AIR MOTOR ASSEMBLY PROCEDURE

FIGURE 2

1. Collect the parts group shown in figure 2. Substitute rebuild kit parts in place of old items where applicable. Install the Valve Bar [21] on the mating diameter of the Detent Spool [20]. Clamp the 5/8" Jam Nut [15] in a bench vise on the flats of the Nut and apply Loctite 638 thread lock to the internal threads of the Jam Nut [15]. Then, Using an adjustable open-end wrench, install and tighten the Detent Spool [20]. Apply 85 in-lb torque.

2. Install the Exhaust Valve Stems [23] into the Valve Bar [21]. Apply Loctite 638 thread lock to the internal threads of the 5/16" Jam Nuts [25] and install on the stems [23] and tighten to 70 in-lbs using two open-end wrenches. It will be necessary to secure the hex cap of the Valve Stem [23] with an open end wrench while securing the first nut. Then install the O-Ring Seals [24] into the gland of the two Valve Stems [23].

FIGURE 3

3. Secure the Rod Head [33] in a bench vise, clamping the part across the flats. Apply Loctite 271 to the internal threads. Install the Trip Rod [32] and tighten to 40 in-lb torque. Use vise grips, applied near the Rod Head, to turn the Trip Rod.
4. Install the following items onto the Trip Rod [32] in the sequence and orientation shown in figure 3: Spring Retainer [14, qty=3], Trip Spring [15, qty=2], assembled parts from stage 1, figure 2.
5. Apply Loctite 271 to the internal threads of the Spring Retainer, Threaded [34]. Install the Spring Retainer, Threaded on the end of the Trip Rod [32] and tighten the entire assembly to 100 in-lbs torque.

FIGURE 4

6. Clamp the Air Piston [18] in a vise, with clamping pressure applied to the 6" diameter on the piston. Note! Use Split wooden or elastic vise blocks matched to the piston diameter to prevent scarring the piston surface!
7. Apply a film of grease in the center cavity of the Air Piston [18]. Insert the assembled parts from assembly stage 2 (per figure 3) into the cavity, oriented as shown in figure 4.
8. Apply a film of grease to the seal gland and o.d. surfaces of the Intake Valves [22]. Install O-Ring Seals [24] on the Intake Valves. Then pass the valves through the ports of the Air Piston [18] and into the mating holes on the Valve Bar [21]. Secure the Valves with 5/16" Jam Nuts [25]. Tighten all Jam Nuts to 70 in-lb torque.
9. Apply a film of grease to the 1/2" Ball [27, qty=2] and Detent Spring [28, qty=2]. Then by hand, apply upward pulling force on the Trip Rod assembly, so that the intake valves [22] are completely closed. With the Trip Rod held in that position, install the 1/2" Steel Ball [27], Detent Spring [28] and Detent Sleeve [29] in each of the two detent ports located on the Air Piston [18]. It will be necessary to unclamp and adjust position of the Air Piston during this procedure.
10. Apply a film of grease to the o.d. seal gland on the Air Piston [18], then install the O-Ring Seal [6]. Remove the Air piston from the vise and apply a film of grease to the 6" diameter piston surface. Set aside the completed subassembly.

FIGURE 5

11. Clamp the Upper Body in a bench vise, oriented with bore horizontal. Use elastic jaw cushions in the vise to prevent scarring the pump surface. Install the Air Motor Subassembly [shown in figure 4] into the Upper Body [2]. Install from the top of the pump, opposite the direction of the 1/2" NPT port on the Upper Body. Slide in carefully, keeping the Air Piston square with the bore of the Upper Body.
12. Install the O-ring Seal [5] into the gland in the Cap [1]. Install the Cap [1] on the top of the Air Motor. When the Cap [1] is installed, it must be shifted sideways approximately 1 inch to allow attachment of the internal Rod Head [33, fig 2] into the slot on the Cap [1].
13. Apply a film of grease to the seal glands on the Center Insert [3]. Install the two O-ring Seals, [5] and [26], in their glands on the Center Insert [3]. Install the Center Insert [3] on the subassembly by sliding it gently onto the Air Piston.
14. If the 5/16" Threaded Studs [7, qty=4] and Acorn Nuts [11, qty=4] have become separated during subassembly, they must be reassembled with adhesive before proceeding further. Clean and degrease the threads of the Stud and Nut. Apply Loctite 271 to the internal threads of the Acorn Nut [11] and install the Nut on the Stud [7]. Using vise-grip pliers to hold the Stud [7] near the Acorn Nut [11], tighten the Nut with a hex wrench to 100 in-lb torque.
15. Install the Studs [7, qty=4] and Acorn Nuts [11, qty=4] as shown in figure 5, into the holes on the subassembly. Using a socket wrench, hold the 1/2" Hex Acorn Nut [11] on the pump Cap [1]. With a second socket wrench, install and tighten the 1/2" Hex Nut [10, qty=4] and Lock washer [9, qty=4] at the other end of the 1/2"-13 Threaded Stud [7]. Leave the Upper Body clamped in the bench vise.

FINAL PUMP ASSEMBLY PROCEDURE:

FIGURE 11

16. Install the Lower Body [4] in position on the Air Motor (from figure 5), with Dowel Pins on the Lower Body oriented away from the Air Motor. Install the Muffler [17] and Diffuser Plate [16] in the counterbore of the Lower Body [4].
17. Install the Bare Lower subassembly on the Air Motor as shown in figure 11. The muffler must be loosened, Pump Rod, muffler, and diffuser plate shifted off-center 1", then moved into position and the Pump Rod locked into the coupler slot on the bottom of the Air Piston. After attachment to the Air Piston, reposition the muffler and diffuser plate then move the flange of the Fluid Adapter into tight contact with the Lower Body. Install the 5/16" Hex Cap Screws [13] and Lock washers [12], then tighten to 100 in-lb torque. Pump assembly is complete.

50:1 GREASE PUMP

PART NO 25740

PARTS LIST

Available service kits:
 900029 Pump Lower Rebuild Kit
 900027 Air Motor Rebuild Kit
 900028 Air Motor Soft Parts Kit

ITEM	PART NO#	DESCRIPTION	QTY IN PUMP	SERVICE KIT QTY		
				900029	900027	900028
1	831791	Cap	1			
2	831763	Upper Body	1			
3	831793	Center Insert	1			
4	831795	Lower Body	1			
5	830695	Seal, O-Ring, -258	2	2	2	
6	806909	Seal, O-Ring, -433	1	1	1	
7	832103	Stud, 1/2-13	4			
8	805718	Washer, Flat, SAE 1/2	4			
9	805841	Washer, Lock, 1/2	4			
10	805813	Nut, Hex, 1/2-13	4			
11	832113	Nut, Hex, Acorn, 1/2-13	4			
12	805844	Washer, Lock, 5/16	4			
13	831677	Nut, Hex, Acorn, 5/16-18	4			
14	832104	Stud, 5/16-18	4			
15	831366	Nut, Hex Jam, 5/8-18	1	1		
16	832228	Diffuser Plate	1			
17	832105	Muffler	1			
18	831799	Air Piston	1			
19	831913	Coupler Rod	1			
20	831660	Spool, Detent	1	1		
21	831759	Valve Bar	1	1		
22	831761	Valve Stem, Intake	2	2		
23	831762	Valve Stem, Exhaust	2	2		
24	831665	Seal, O-Ring, Polymod, -110	4	4	4	
25	831764	Nut, Hex Jam, 5/16-18	8	8		
26	831367	Seal, O-Ring, -345	1	1	1	
27	813905	Ball	2	2		
28	807939	Spring	2	2		
29	831914	Sleeve, Detent	2	2		
30	831766	Spring	2	2		
31	831767	Retainer, Spring	3	3		
32	831768	Trip Rod	1		1	
33	831769	Rod Head	1		1	
34	831770	Retainer, Spring, Threaded	1		1	
35	830641	Label, Eurolube	1			
36	830350	Label, Warning	1			
37	832114	Lifting Eye	1			
38	832117	Fluid Adapter, Drum pump	1			
	832256	Fluid Adapter, Stub pump				
39	832132	Seal Adapter	1			
40	832135	Seal Carrier	1			
41	832134	Seal Retainer	1	1		
42	832133	Rod Guide	1	1		
43	830678	Seal, Ultrathane	1	1		
44	832131	Pump Tube - 400lb. drum	1			
	832254	Pump Tube - Stub Tote				
45	832128	High Pressure Cylinder	1			
46	832127	Primer Cylinder	1			
47	830676	Port Extension	1			
48	832116	Upper Rod	1			
49	832126	Lower Rod - 400lb drum	1			
	832255	Lower Rod - Stub Tote				
50	808324	Spring	1	1		
51	832125	Piston Nut	1			
52	806167	Ball	1			
53	830679	Seal, Ultrathane	1	1		
54	832123	Primer Rod	1			
55	832124	High Pressure Piston	1			
56	830677	Seal Retainer	1	1		
57	830680	Seal, Ultrathane	1	1		
58	812166	Piston	1			
59	805715	Nut, Hex 1/2-20	1			
60	832129	Primer Valve	1			
61	832130	Retaining Ring	1	1		
62	831489	Grounding Lug (not shown)	1			

50:1 GREASE PUMP

PART NO 25740

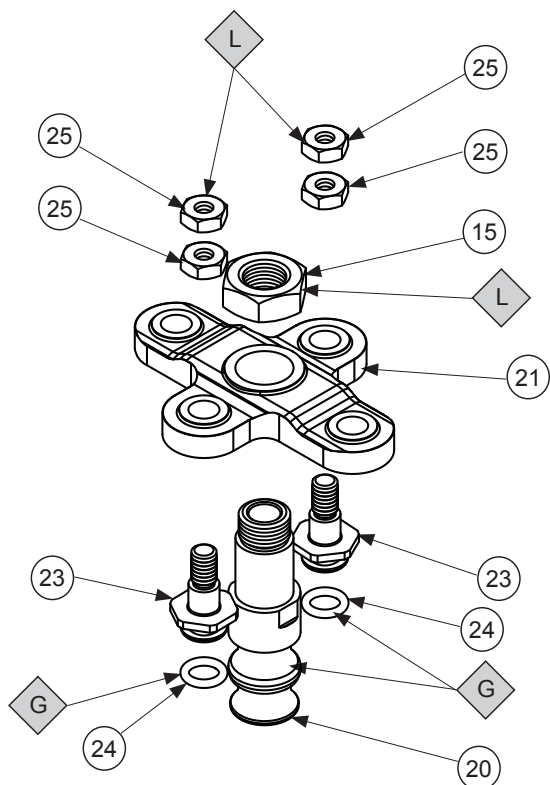

Figure 2
Head Assembly
Assembly Stage 1

Exploded Views Air Motor

(25)	- Item number
G	- Grease application point, see detail in written procedure
L	- Loctite application point, see detail in written procedure

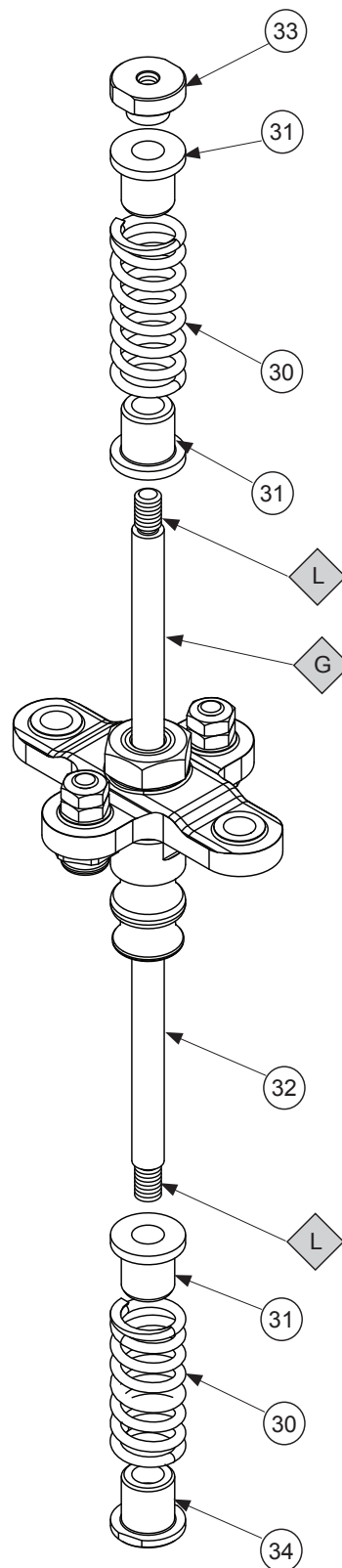
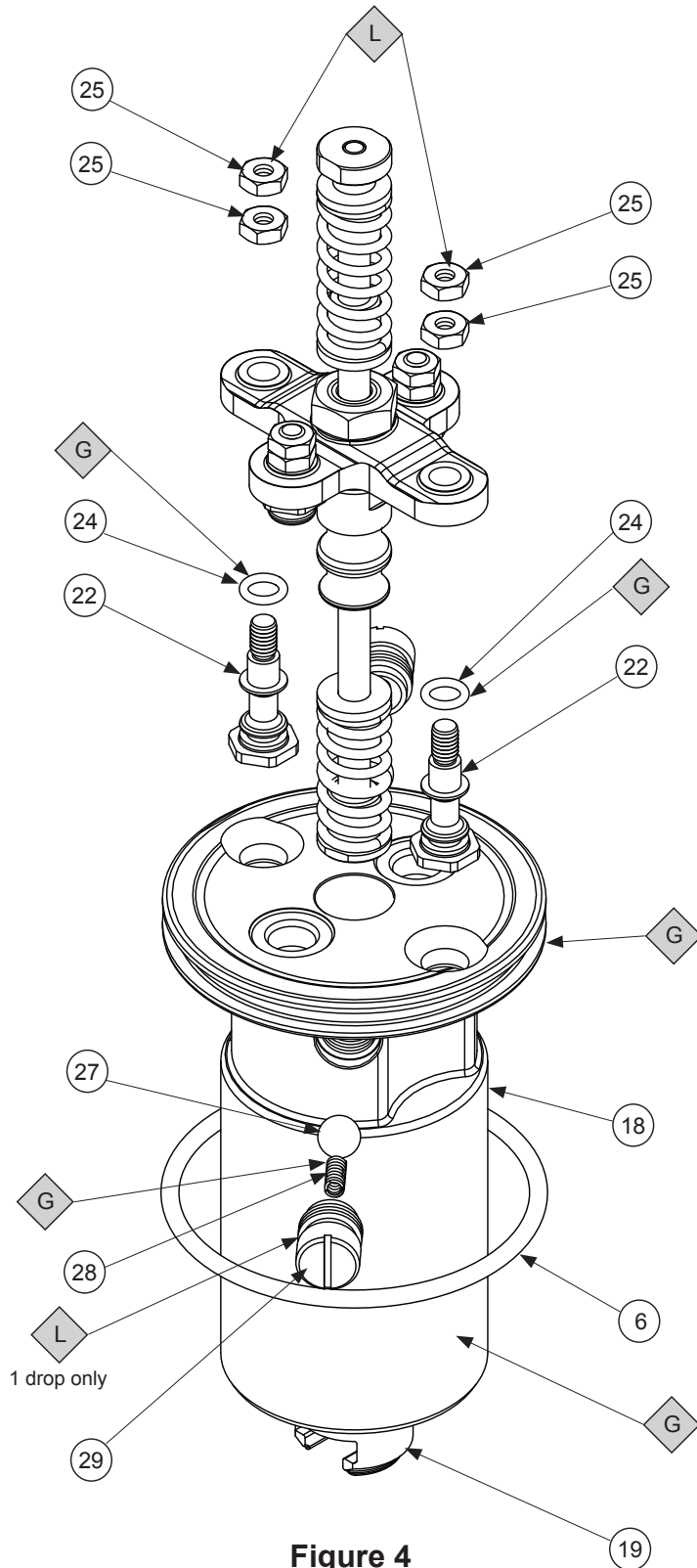

Figure 3
Head Assembly
Assembly Stage 2

50:1 GREASE PUMP

PART NO 25740



Exploded Views Air Motor

- 25 - Item number
- G - Grease application point, see detail in written procedure
- L - Loctite application point, see detail in written procedure

Figure 4
Head Assembly
Assembly Stage 3

50:1 GREASE PUMP

PART NO 25740

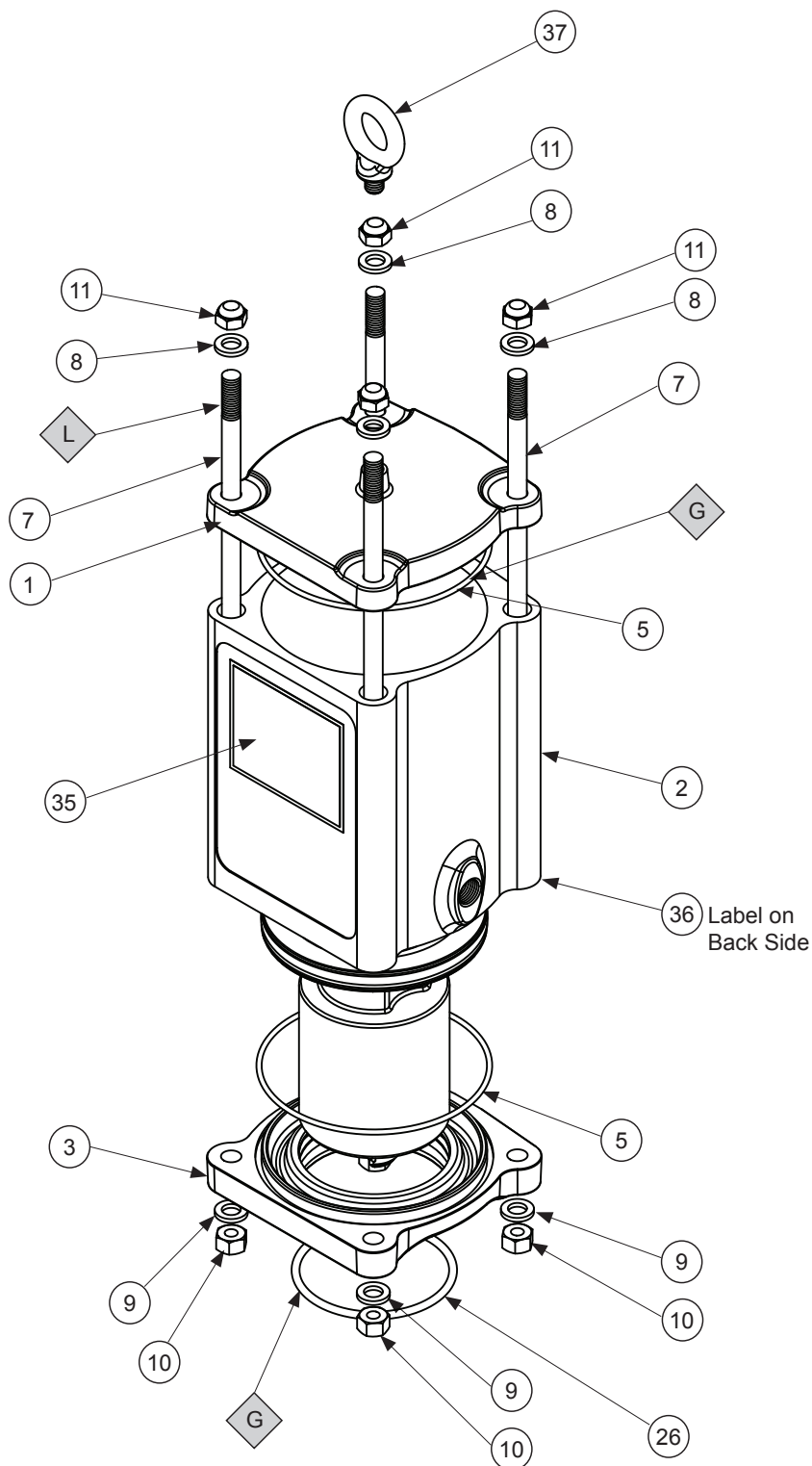

Exploded Views Air Motor

25	- Item number
G	- Grease application point, see detail in written procedure
L	- Loctite application point, see detail in written procedure

Figure 5
Head Assembly
Assembly Stage 4

50:1 GREASE PUMP

PART NO 25740

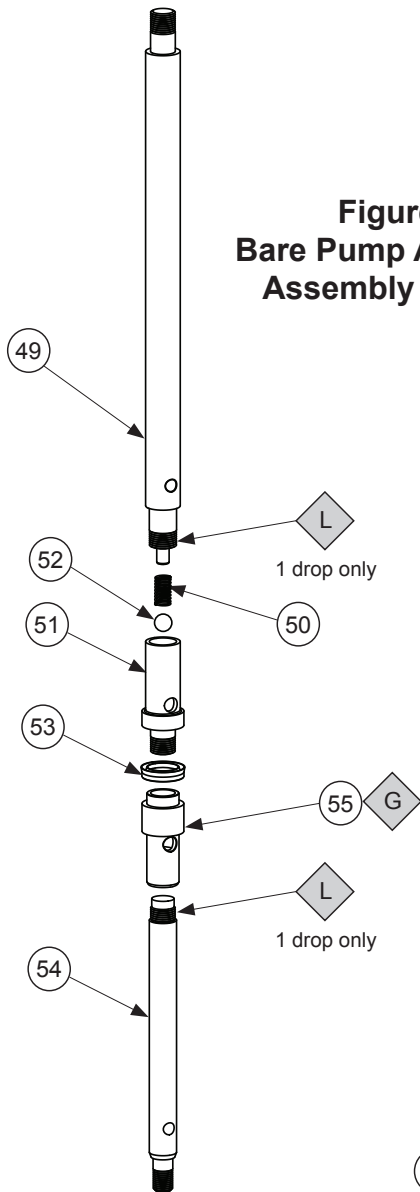

Figure 7
Bare Pump Assembly
Assembly Stage 6

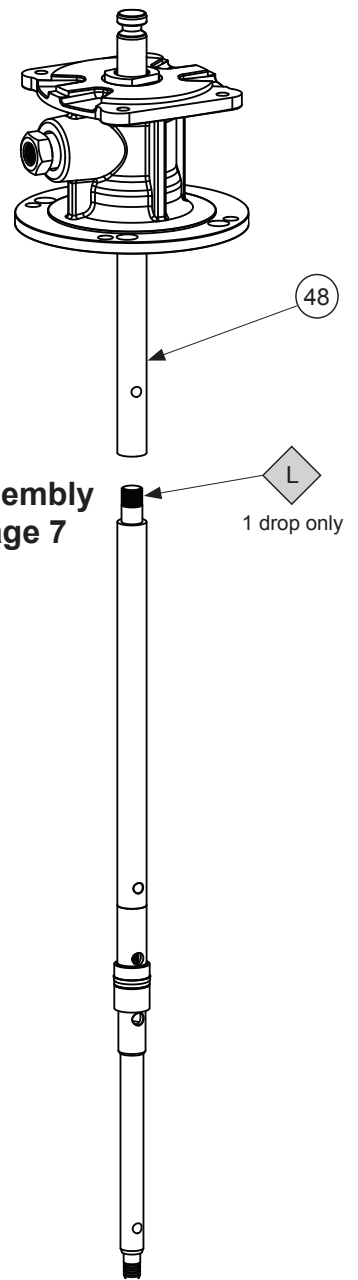

Figure 8
Bare Pump Assembly
Assembly Stage 7

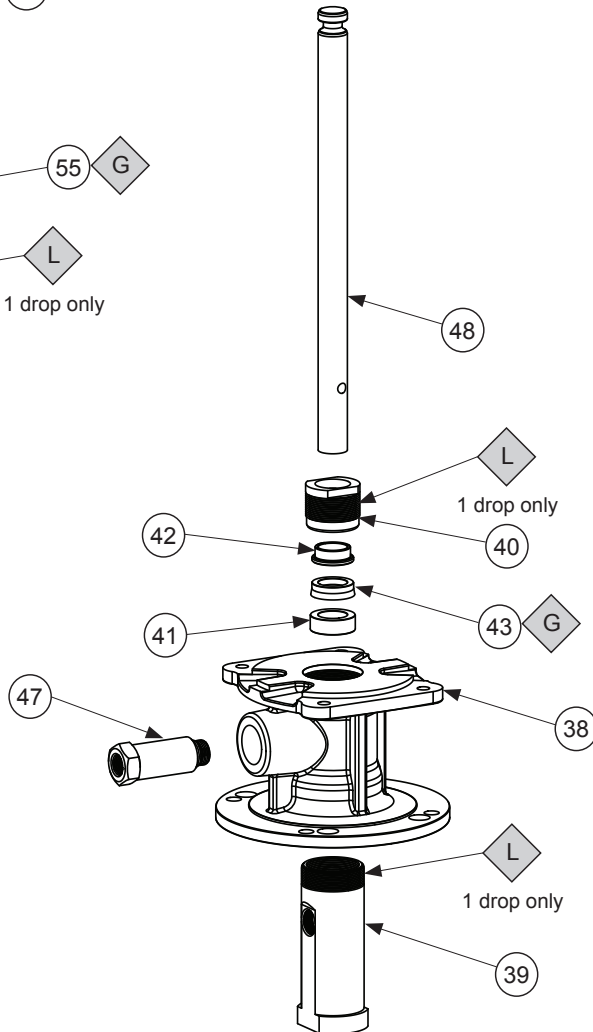

Figure 6
Bare Pump Assembly
Assembly Stage 5

Exploded Views Lower Assembly

	- Item number
	- Grease application point, see detail in written procedure
	- Loctite application point, see detail in written procedure

50:1 GREASE PUMP

PART NO 25740

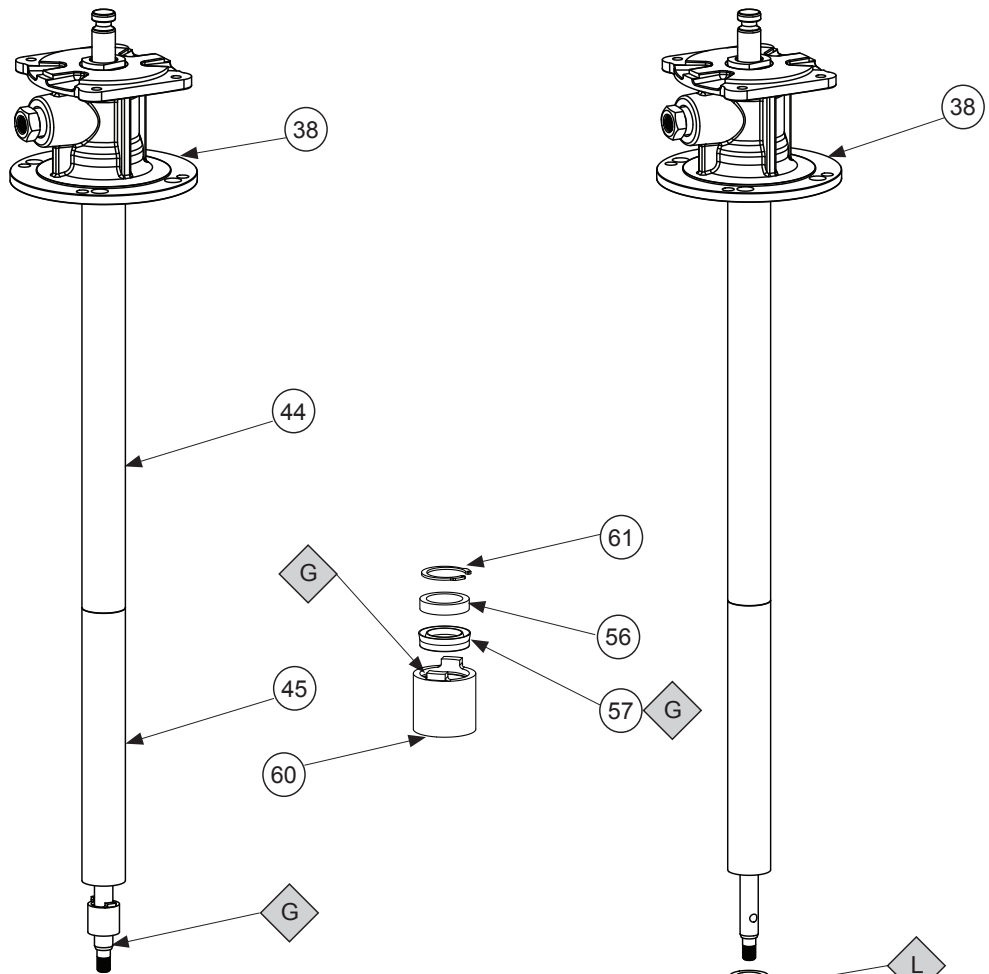

Figure 9
Bare Pump Assembly
Assembly Stage 8

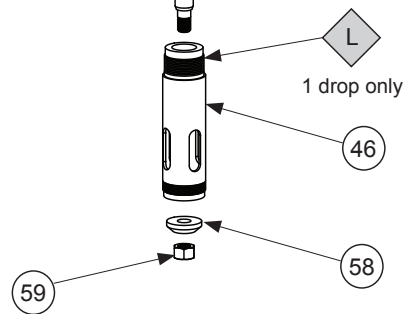

Figure 10
Bare Pump Assembly
Assembly Stage 9

Exploded Views Lower Assembly

25	- Item number
G	- Grease application point, see detail in written procedure
L	- Loctite application point, see detail in written procedure

50:1 GREASE PUMP

PART NO 25740

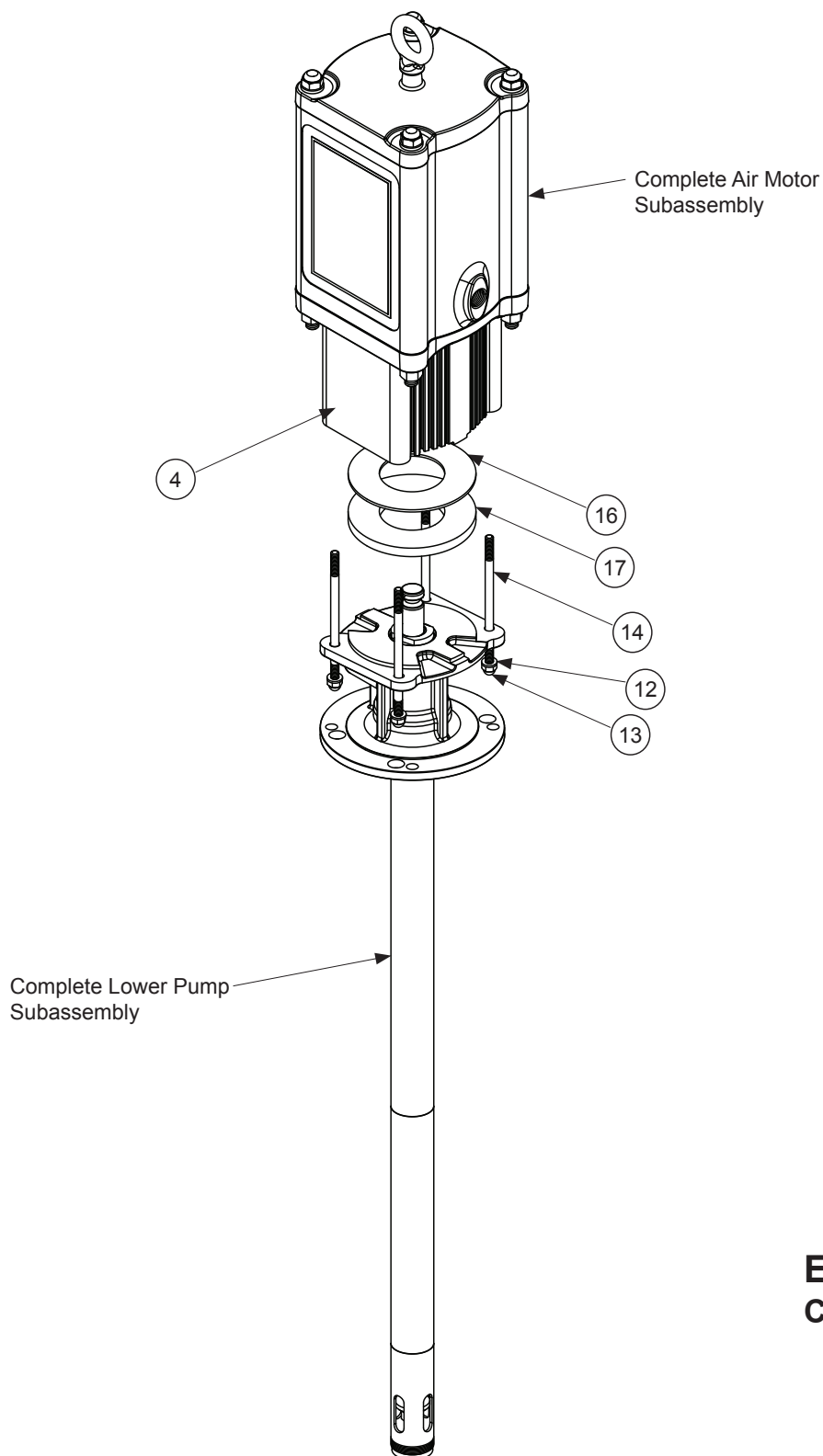

Figure 11
Final Pump Assembly
Assembly Stage 10

Exploded Views Complete Pump

25	- Item number
G	- Grease application point, see detail in written procedure
L	- Loctite application point, see detail in written procedure

50:1 GREASE PUMP

PART NO 25740

Troubleshooting

SYMPTOM	POSSIBLE REASON	SOLUTION
Pump does not operate	Inadequate air supply pressure or restricted air line Clogged lines, hoses, valves, etc Damaged air motor	Increase air line size or clean air supply. Assure air is on and valves are open Open; clear Service / replace air motor
Air motor is not tripping over	Air motor seals are worn/damaged	Service / replace air motor / ensure a filter is used on air inlet to pump
Air is leaking from exhaust and/or seal damage, etc	Air motor seals are worn/damaged	Service / replace air motor / ensure a filter is used on air inlet to pump
Fluid is leaking from the exhaust	Fluid seal [43, fig 8] is worn/damaged	Replace fluid seal
Erratic pump operation	Air entering suction line Fluid level too low Air motor icing	Check follower plate Refill, reprime or flush Run pump at lower pressure, run at lower cycles per minute; clean muffler [17]
Pump runs continuously	Empty fluid supply Blockage in primer tube [46] Ball [52] is stuck in piston nut [51] Lower seal [53] is worn or damaged	Refill, reprime or flush Remove primer tube, clear blockage Replace ball and reseal piston nut Replace
Pump operates slowly, and pump output on both strokes is low	Inadequate air supply pressure or restricted air line Closed or clogged dispensing valve Air inlet strainer/filter clogged	Increase air supply; increase air supply size Clear Clear

PRODUCT SAFETY INSTRUCTIONS

- The pump is intended for non-corrosive and petroleum based liquids. It may NOT be used for other purposes or for pumping gasoline, or other explosive liquids.
- Check that all components used are suitable for the operating pressure of the system.
- Do not use higher pressure than required for the satisfactory functioning of the system.
- Before a system is put into operation it is recommended that the system be pressurized to 1,3 times max. working pressure.
- Before work is undertaken on the pump the compressed air should be disconnected from the pump and the whole system should then be depressurized.
- Check all components thoroughly for damage and leakage.
- Ensure that the compressed air is disconnected from the pump and the system is depressurized when system is not in use i.e. overnight or during longer shut down periods as there is always a risk of hoses bursting or pipework leaking etc.

General

The pump is made up of two main parts: A compressed air operated two way piston air motor and a double acting liquid pump. The liquid is sucked into the pump tube via the bottom valve. When the piston moves upwards liquid is forced out of the fluid outlet. The fluid is forced out of the pump when the piston is moving in both directions. The relationship between the air piston and the pump piston determines the ratio of the pump. If the pump ratio is 50:1 the theoretical fluid pressure will be 50 times to the air pressure, when the pump stalls out. The air is exhausted from the pump via a sound attenuator.

Installation/Operation

- To achieve long pump life we recommend that filter regulator to be installed prior to the air inlet of the pump.
- Remove the protective packaging from the pump and also the protective plugs.
- Fit the 2" pump adaptor firmly on to the barrel.
- Mount the pump into the pump adaptor and lock into position.
- Fit and secure the outlet hose.
- Fit and secure the air inlet hose, slowly increase the air pressure letting the pump slowly build up fluid pressure.
- Ensure there are no leaks either on the air inlet or at the fluid outlet. To obtain maximum vacuum all connections should be sealed and tight.
- Slowly increase the air pressure to optimum working pressure.

Warning! The maximum permitted air pressure is 10bar, do not exceed this limit. Service: Before any service-work is carried out the compressed air must be turned off to the pump or the air coupling disconnected. And the fluid outlet must be depressurized completely.

Maintenance

- Before any service work is carried out the compressed air must be turned off to the pump or the air coupling disconnected. And the fluid outlet must be depressurized completely.
- Clean the air filter, remove all pollutants including condensed water.
- Check system for any air or fluid leaks.
- Always keep the equipment clean and remove foreign objects, ensure no pollutants enter the barrel as these will be pumped into the system.
- When changing the barrel make sure the pump remains clean (Do not put on to floor otherwise the grease will become polluted).
- When depressurizing the system or removing the outlet hose from the pump ensure there is a container available to drain the excess grease into.

Service

- For your personal safety ensure the air is disconnected from the pump, and the fluid discharge is depressurized before any service is carried out. Be cautious when repressurizing the system after any service work is carried out.
- During service procedures it is important to avoid any scratching or any other damage to gasket or bearings surfaces. Keep tools and benches clean. Be extremely cautious when assembling or dismantling V-packings and O-rings. Exchange all worn or damaged parts no matter how slightly damaged they seem.
- Clean and grease all gasket, bearing surfaces including O-rings and gaskets with teflon grease when reassembling pump.
- Try to use paraffin to clean pump parts. If water based cleaners are used, wipe parts clean & dry immediately to avoid corrosion.

DECLARATION OF CONFORMITY

EuroLube Equipment AB, Stråsavägen 2, SE-71176 Storå, Sweden, declares hereby that the products:
Air operated grease pump, model: 25740 Are in conformity with the requirements of the Council's Machinery Directive 2006/42/EC.

Storå Juni 20, 2011



Morgan Gustavson,
Product director (Authorized representative for EuroLube Equipment AB and responsible for technical documentation).



EUROLUBE EQUIPMENT AB

Stråsavägen 2, SE-711 76 Storå, Sweden

EMAIL eurolube@eurolube.com PHONE +46 581 836 65 FAX +46 581 409 75

 www.eurolube.com